

EGOTERIC

Analog Turntable

Grandioso T1



ANNIVERSARY
1987-2022

– Revolution Begins. –

In the dead silence of the “Esoteric MagneDrive System”
you will hear the sounds of a revolution taking place,
making history for vinyl playback.

Grandioso T1

Analog Turntable

ESOTERIC MagneDrive System

A new undertaking to commemorate the 35th Anniversary of the Esoteric legacy; it's the first-ever turntable in our history, the Grandioso T1.

Accommodating a patent-registered unique contact-free drive mechanism, the “Esoteric MagneDrive System”, that inductively synchronizes the rotations of a magnetic driver and platter, realizing a quiet and silky-smooth rotation at an extraordinarily accurate rotation speed.

This turntable – with 10MHz Clock Sync capability for the motor drive unit and 3 piece independent chassis configuration – is the culmination of Esoteric's unique design philosophy and mechanical/electronic technology.



Newly Developed
Contact-Free Drive Mechanism

ESOTERIC MagneDrive System

Japan Patent No. 6501130

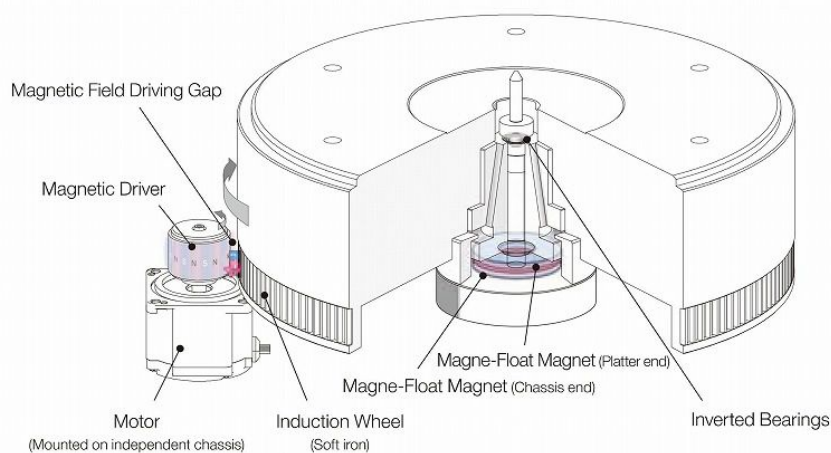

Technical Highlights

1. The Platter is free from any vibration.
2. Absolutely precise platter rotation, free from any irregularities of speed, potentially caused by mechanical contacts, such as belt, rim or motor.
3. Adjustability of sonic characteristics, by manually changing the distance between the platter and the driver.
4. No concern for the need of replacement belts.



Grandioso T1 Analog Turntable

Key Features

- Esoteric's patented contact-free drive system "Esoteric MagneDrive System"
- Magne-Float platter greatly reduces spindle bearing friction by reducing platter's effective mass from 19kg down to approx. 4kg.
- Consists of 3 separated units: main unit, motor unit, and power supply unit.
- High quality VCXO motor driver ensures precise platter rotation.
- 10MHz Clock Sync capability with the Grandioso G1X Master Clock.
- Inverted bearing system supports smooth rotation of the platter.
- The Micrometer knob on the front panel provides fine-tuning capability of sonic characteristics, by adjusting the strength of magnetic force being applied from the magnetic driver to the platter.
- Triple layer chassis made of Aluminum and wood, effectively controls vibration.
- The mid-chassis is applied with beautiful high gross piano lacquer.
- The isolation feet have a special damping mechanism that eliminates external vibration.
- Two speed control (33/45 rpm), adjustable with 0.1% order.
- The T1 is offered with TA-9D dynamic balance tonearm, or without tonearm configuration.
- Optional arm-board allows the T1 accommodates up to 3 tonearms.

● Overall Dimensions	(Main Unit)	497 x 210 x 456mm (HxWxD)	
	(Power Supply Unit)	445 x 132 x 270mm (HxWxD)	
● Weight	(Main Unit)	45kg	Main Chassis 17kg Platter 19kg Motor Unit 9kg
	(Power Supply Unit)	18kg	

Esoteric Company

1-47, Ochiai, Tama-shi, Tokyo Japan 208-8530
<https://www.esoteric.jp/en>



Design and specifications subject to change without notice. ©2022 Esoteric Company. All Rights Reserved. All text, images, graphics and other materials on this brochure are subject to the copyright and other intellectual property rights of Esoteric Company. These materials shall not directly or indirectly be published, reproduced, modified or distributed in any medium. Esoteric is a trademark of TEAC Corporation, registered in the U.S. and other countries. Grandioso is a trademark of TEAC Corporation. All other brand or product names are trademarks or registered trademarks of their respective holders.